

# MT-2H

## *Semi-Automatic Hot Mounting Machine*

MOUNTING



2023

08 / 21

# MT-2H Semi-Automatic Hot Mounting Machine

MT-2H is a semi-automatic hot mounting machine, suitable for thermoforming of different materials, such as epoxy resin, bakelite powder, acrylic powder, etc. Adopting dual-sleeve design, the left and right sleeves can be controlled individually to meet the needs of batch mounting for different sizes of specimens.



## Features:

- ◆ Sliding caps for easier and safer operation;
- ◆ Low running noise and small overall size;
- ◆ The 7-inch touchscreen has a clean, easy-to-use interface;
- ◆ Real-time display of temperature and pressure changes;
- ◆ The LED light strip indicates the running status;
- ◆ Multiple sets of operating parameters can be stored.

## Technical Specifications:

Model		MT-2H
Electric	Power supply	220V, 50Hz (110V customizable)
	Power	4.0Kw
Sample	Dimension	Φ25.4mm, Φ30mm, Φ32mm, Φ40mm, Φ50mm (or customized)
	Max. height	80mm
Heating	Heating range	~200°C
	Holding time	0 ~ 30Min
	Heating part	Surrounded
Pressurization	Pressure range	0~300Bar (Related to the size of the sleeve)
Cooling	Cooling method	Automatic mode: by time/temperature; manual mode.
	Cooling rate	High, medium and low cooling rate
	Diameter of inlet pipe	OD=Φ8mm, water pressure<0.3MPa
	Diameter of outlet pipe	ID=Φ12mm
Control panel		7-inch touch screen
Noise	Measured at 1 meter	<60dB
Operating environment	Temperature	-20°C - 60°C
	Humidity	0-95%RH
Dimension	WxDxH	660x500x500mm
Weight		58Kg

## Control Panel Introduction:



- ① Current program
- ② Time
- ③ Back to program page
- ④ Display heating temperature
- ⑤ Display holding time
- ⑥ Display set pressure
- ⑦ Display cooling time
- ⑧ Display cooling temperature
- ⑨ Display cooling rate
- ⑩ Parameter setting
- ⑪ Cool down
- ⑫ Program library
- ⑬ Rise
- ⑭ Decline
- ⑮ Start/Stop
- ⑯ Temperature curve
- ⑰ Pressure curve

## Dimension Figure

Unite: mm

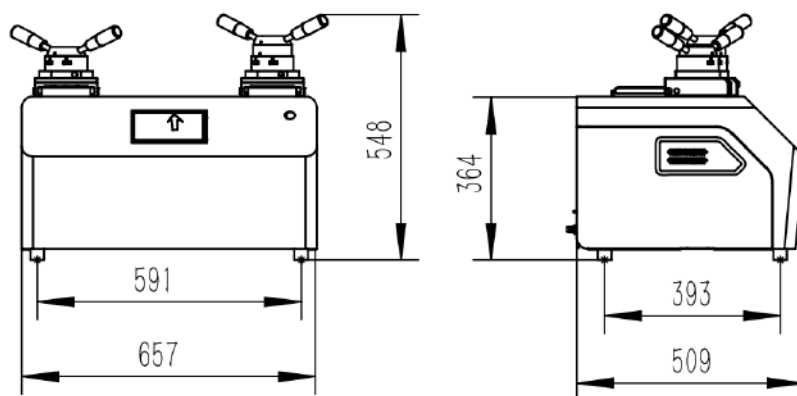

## Related Consumables & Accessories:

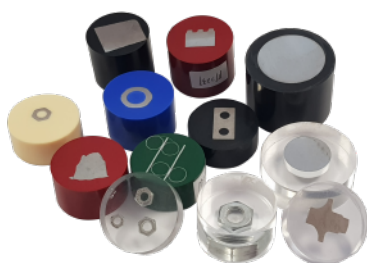

Hot Mounting Consumables













Mineral & Glass Fiber Filled Epoxy Resin



Sample Support Clip

## Technical Specifications:

1	Water inlet pipe		Φ8mmPU pipe	1pc
2	Water outlet pipe		Inner diameter 12mm, outer diameter 21mm, drain hose and hose clamp	1set
3	Hot mounting compounds		PT-2231,300g	1bottle
4	Spoon			1pc
5	Funnel			1pc
6	Cleaning brush			1pc
7	Shovel			1pc
8	Storage box			1pc
9	Allen key		M5 Allen key	1pc
10	Power cable		220V, 16A, 1.5Mhigh-power power cable	1pc

## Optional accessories:

1	Circulating tank		Capacity45L, flow 5L/min	1set
2	Sleeve and the rams		Φ25.4、Φ30、Φ32、Φ40、Φ50	1set
3	Mold release			1bottle
4	Brass spacer		Φ25.4、Φ30、Φ32、Φ40、Φ50	1pc

## Purchase list:

### Hot Mounting Consumables:

02.01.310/320	PT-2231 Phenolic Resin Black (Daily Use)	1kg/4kg
02.01.311/321	PT-2231 Phenolic Resin Green (Daily Use)	1kg/4kg
02.01.312/322	PT-2231 Phenolic Resin Red (Daily Use)	1kg/4kg
02.01.210/220	BB-2232 Phenolic Edge Protection Resin	1kg/4kg
02.01.110/120	TM-2235 Transparent Resin	1kg/4kg
02.01.710/720	EP-2237 Mineral & Glass Fiber Filled Epoxy Resin	1kg/4kg
02.01.910/940	DC-2239 Graphite Conductivity Hot Insert Resin	1kg/4kg
02.01.960/965	MA-2275 Mineral filled Melamine Resin	1kg/4kg

### Accessories for hot mounting:

12.01.042	Mold release agent	100g
07.01.016	Stainless Steel Clip	100pcs



TROJAN (SUZHOU) MATERIAL TECHNOLOGY CO.,LTD

Tel: +86-512-65283666

Email: [sales@trojanchina.com](mailto:sales@trojanchina.com)

Web: [www.trojanworld.com](http://www.trojanworld.com)

Add: Building 26, No.228 Gongtang Road, Luzhi Town, Wuzhong Suzhou, China

