

CT - 150A Low-Speed Precision Cutting Machine

CUTTING



2026

03 / 16

CT - 150A Low-Speed Precision Cutting Machine

CT-150A Low-Speed Precision Cutter is designed for precision cutting of various hard materials, and is especially suitable for accurate sectioning of small metal and non-metal components as well as electronic parts. The machine can be equipped with diamond blades or resin-bonded blades of other materials to meet cutting requirements for different specimen types. A variety of specimen fixtures are available, enabling the workpiece to be positioned at the optimal angle for cutting, and allowing precise fine adjustment of the horizontal feed position. It is an ideal metallographic pre-preparation solution for laboratories in universities, research institutes, and industrial production facilities.

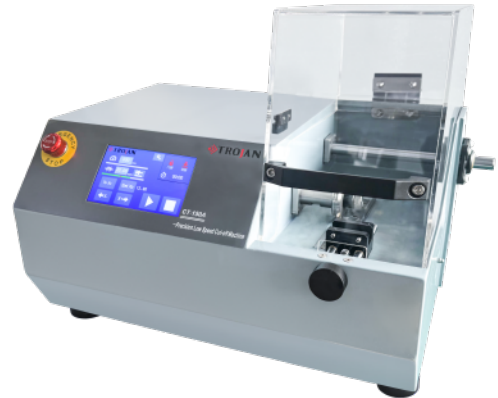

Features:

- ◆ Adjustable cutting wheel speed: 50–600 rpm.
- ◆ Constant-speed cutting achieved by adjusting the counterweight.
- ◆ 5-inch touchscreen with program control for convenient operation.
- ◆ Segmented precision cutting function along the X-axis.
- ◆ Quick specimen clamping with accurate positioning.
- ◆ Multiple fixtures included, suitable for cutting irregular-shaped workpieces.

Technical Data:





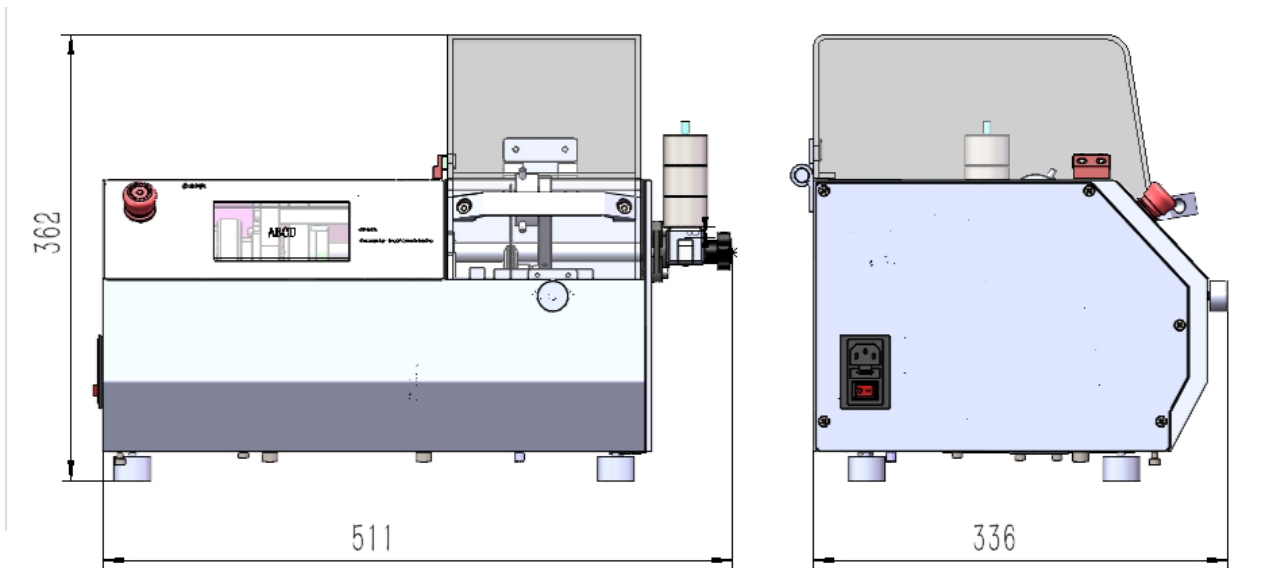

Model		CT-150
Cutting wheel	Speed	50-600rpm
	Diameter	Φ100-150mm
	Arbor Hole	Φ12.7mm
Electrical	Voltage	220 V / 50 Hz / 110V/60HZ
	Motor Power	0.5kw
	Touchscreen	5 inch
	X-axis Feed	Automatic feed
Cutting Capacity	Max. Cutting Diameter	Ø40mm
	X Travel	X-axis (left/right): 50mm
		0.02mm
Dimensions	W×D×H	510×340×360mm
Weight		30kg

Dimension Figure

Unite: mm

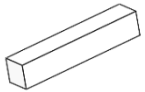

Technical Specifications:

1	Wrench		19/17 open-end wrench	1pc each	
2	Flange		Ø50	1 set	Includes 2 fixing plates
3	Fixing plate nut			1 pc	
4	Power cable		1.5 m	1 pc	
5	Cutting fluid		500 ml	1 bottle	
6	Aluminum oxide cutting wheel		150 × 12.7 × 0.5	10 pcs	A601505
7	DP electroplated diamond cutting wheel		150 × 12.7 × 0.5	1 pc	DP151305
8	White alumina dressing stone			2 pcs	

Related Consumables & Accessories:



cutting wheel



diamond blade



cutting fluid

fixture accessories:



V-Block Workpiece Clamp



Irregular Workpiece Clamp

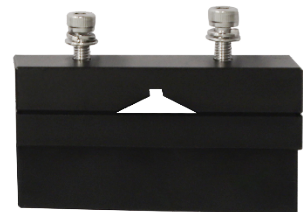

Large V-Block Workpiece Clamp



Teardrop Workpiece Clamp



Quick-Release Workpiece Clamp



Double V-Block Workpiece Clamp



Round Specimen Clamp (1.5")



Round Specimen Clamp (1.25")

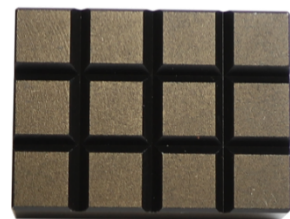

Adhesive Mounting Clamp



TROJAN (SUZHOU) MATERIAL TECHNOLOGY CO.,LTD

Tel: +86-512-65283666

Email: sales@trojanchina.com

Web: www.trojanworld.com

Add: Building 26, No.228 Gongtang Road, Luzhi Town, Wuzhong Suzhou, China

